

产品承认书

SAMPLE APPROVAL SHEET

产品名称: 声表面滤波器

Product Name: SAWF

产品型号: R418M

Product Model: R418M

产品体积: TO-39-DIP

Product volume: TO-39-DIP

承认后请回传一份

PLS SEND BACK ONE COPY TO US AFTER YOUR APPROVAL

承认结果 CONCLUSION	客户签名 SIGNATURE	客户承认章 STAMP	日期 DATE	备注 REMARK
合格 ACCEPT				
不合格 REJECT				

制表: 童娟

审核: _____
(公章)

尊敬的客户:请您抽取一点时间,在7-10个工作日内将承认书回签,若未回签,已视默认.谢谢合作!!!

1. Package Dimension (TO-39/3A)

Unit: mm

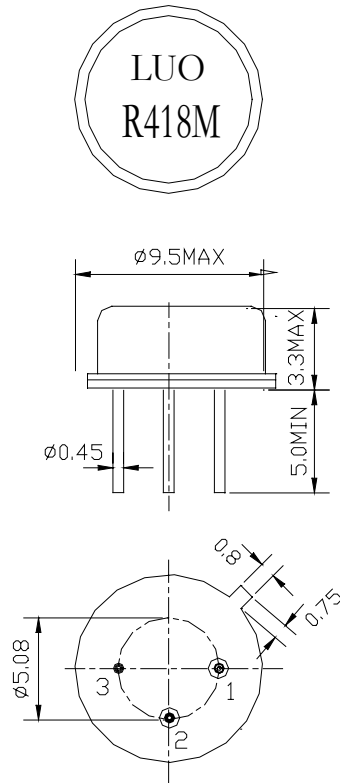

Pin No.	Function
1.	Input
2.	Output
3.	Ground

2. Marking

LUO
R418.00

1. Color: Black or Blue
2. DR: Manufacture's logo
3. 1: One-port SAW Resonator
4. 418.00: Center Frequency (MHz)

3. Equivalent LC Model

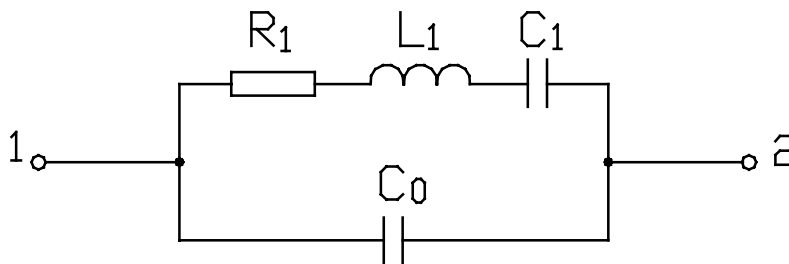

4. Performance

4.1 Maximum Rating

DC Voltage V_{DC}	10V
AC Voltage V_{PP}	10V (50Hz/60Hz)
Operation Temperature	-40 to +85
Storage Temperature	-45 to +85
RF Power Dissipation	0dBm

4.2 Electronic Characteristics

Item	Units	Minimum	Typical	Maximum	
Center Frequency	MHz	417.925	418.00	418.075	
Insertion Loss	dB	—	1.2	2.5	
Quality Factor	Unloaded Q	—	12,100	—	
	50 Loaded Q	—	2,000	—	
Temperature	Turnover Temperature	20	35	50	
Stability	Turnover Frequency	KHz	f_0	—	
	Freq. Temp. Coefficient	ppm/°C ²	—	0.032	—
Frequency Aging	ppm/yr	—	<±10	—	
DC Insulation Resistance	M	1.0	—	—	
RF Equivalent RLC Model	Motional Resistance R_1	—	20	26	
	Motional Inductance L_1	μH	—	91	—
	Motional Capacitance C_1	fF	—	1.6	—
	Shunt Static Capacitance C_0	pF	—	2.0	2.3

4.3 Frequency Characteristics

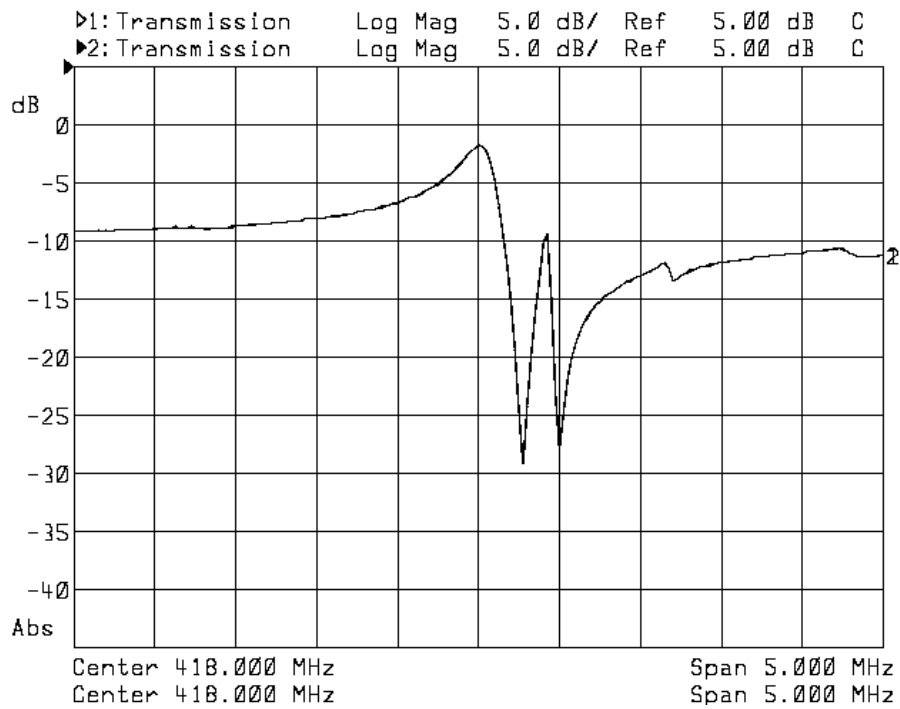

4.4 Test Circuit

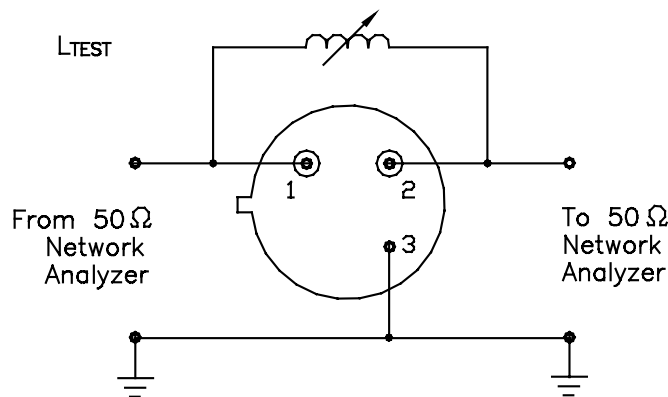

Note: Reference temperature shall be 25 ± 2 . However, the measurement may be carried out at 5 to 35 unless there is a dispute.

5. Reliability

5.1 Mechanical Shock: The components shall remain within the electrical specifications after 1000 shocks, acceleration 392 m/s^2 , duration 6 milliseconds.

5.2 Vibration Fatigue: The components shall remain within the electrical specifications after loaded vibration at 20 Hz, amplitude 1.5 mm, for 2 hours.

5.3 Terminal Strength: The components shall remain within the electrical specifications after pulled 2 kgs weight for 10 seconds towards an axis of each terminal.

5.4 High Temperature Storage: The components shall remain within the electrical specifications after being kept at the 85 ± 2 for 48 hours, then kept at room temperature for 2 hours.

5.5 Low Temperature Storage: The components shall remain within the electrical specifications after being kept at the -25 ± 2 for 48 hours, then kept at room temperature for 2 hours.

5.6 Temperature Cycle: The components shall remain within the electrical specifications after 5 cycles of high and low temperature testing (one cycle: 80 for 30 minutes 25 for 5 minutes -25 for 30 minutes)than kept at room temperature for 2 hours.

5.7 Solder-heat Resistance: The components shall remain within the electrical specifications after dipped in the solder at 260 for 10 ± 1 seconds, then kept at room temperature for 2 hours. (Terminal must be dipped leaving 1.5 mm from the case).

5.8 Solder Ability: Solder ability of terminal shall be kept at more than 80% after dipped in the solder flux at 230 ± 5 for 5 ± 1 seconds.

6. Remarks

6.1 Static voltage

Static voltage between signal load & ground may cause deterioration & destruction of the component. Please avoid static voltage.

6.2 Ultrasonic cleaning

Ultrasonic vibration may cause deterioration & destruction of the component. Please avoid ultrasonic cleaning.

6.3 Soldering

Only leads of component may be soldered. Please avoid soldering another part of component.